



RM10C

HYBRID RECORDER

OUTLINE

RM10C is 100mm calibrated hybrid recorder in a 144x144 DIN front panel and short depth of 150mm case housing. The recorder has versatility of universal input and scale in wide ranges and flexibility of user-reconfigurable unique functions. RM10C offers 1, 2 continuous pen and 6 dot point models.

FEATURES

- Short case depth size of 150mm
- IP65: Dust-proof, Water-proof
- Wide LED with 18mm heights display
- Allows user-selected consumables
- RS-232C communication interface in standard specifications
- UL, C-UL, CE approved
- Weights only 1.5kg (Multipoint type)
- Optional portable housing case available



SPECIFICATIONS

● Input signal

DC voltage:

± 10, 0 ~ 20, 0 ~ 50, ± 200 mV DC, ± 1, 0 ~ 5, ± 10 V DC

Thermocouple:

B, R, S, K, E, J, T, C, Au-Fe, N, PR40-20, PLII, U, L

Resistance temperature detector: Pt100, JPt100

DC current: 4 ~ 20mA DC

(with external shunt resistor: 250Ω
<Charged: HMSU3081A11>)

● Performance

Accuracy: See RANGE TABLE

Dead band: Within 0.2% (Pen Model only)

Input impedance:

10MΩ min. in mV, TC input;
200kΩ min. in mV, TC input (with burnout protection);
1MΩ min. in Voltage input;
250Ω (External shunt resistor) in mA input

Allowable signal source resistance:

10kΩ max. in mV, TC input;
100Ω max. in mV, TC input (with burnout protection);
1kΩ max. in Voltage input;
10Ω max. per line in RTD input

Normal mode reduction ratio: 60dB min. (50/60 ± 0.1Hz)

Common mode reduction ratio: 140dB min. (50/60 ± 0.1Hz)

Isolation resistance: 0.5kV DC 20MΩ min. between the each terminal and grounding terminal

Dielectric strength:

1.5kV AC for 1 minute between power terminal and grounding terminal;
0.5kV AC for 1 minute between input terminal and grounding terminal;
0.2kV AC for 1 minute between the input terminals

Inter channel maximum noise voltage:

200 V AC at 50/60 Hz

Vibration resistance: 10 ~ 60Hz 1m/s² max.

Shock resistance: 2m/s² max.

Clock precision: ± 50ppm max.

Chart feed accuracy: ± 0.1% max.

● Structure

Mounting: Panel mount

Allowable backward inclination: Within 30°

Material (Color):

Case, Polycarbonate (Black), Glass 10% UL94-V2;
Door, Polycarbonate, UL94-V2 (Clear)
Dust-proof, Water-proof
(Complies with the IEC529-IP65)

● Power Supply Voltage

Power voltage (rated): 100 ~ 240V AC

Power voltage: 85 ~ 264V AC

Frequency (rated): 50/60Hz

Frequency: 45 ~ 65Hz

● **Normal Operating Conditions**

Ambient temperature: 0 ~ 50°C

Ambient humidity: 20 ~ 80%RH

Supply voltage: 85 ~ 264V AC

● **Alarm (Relay output is optional)**

Alarm types: 2 types(H,L),4 levels/channel

Alarm output: 250 V AC, 3 A max. (resistance load)
 125 V DC, 0.5 A max.(resistance load)
 30 V DC, 3 A max.(resistance load)

Hysteresis width: 0.5 ± 0.2 %

Setting accuracy: ± 0.5 %

Outputs:

- Pen Model, 3 point (Built-in option, normally open);
- Multipoint Model, 6 point (Built-in option, normally open)

● **Safety Standard and EMI Standard**

Electrical safety:

- IEC1010-1,UL3101-1 installation category II and pollution degree 2.
- UL3101-1

Emissions: EN55011 Group1 Class A

Immunity: EN50082-2

RS-232C (Standard): 1200, 2400, 4800, 9600

RS-485 (Option): 1200, 2400, 4800, 9600

● **DI function**

Function	Description
Chart Feed Start/Stop	Close: Starts Open: Stops
Change Chart Speed	Close: Chart speed 1 Open: Chart speed 2
Comment Print	Prints programmed characters (Multipoint model is up to 16 characters per line. Pen model is up to 12 characters per line.)
Manual Print	Close: Start to print
Date and Time Print	Close: Start to print

Up to 3 functions among above can be selected in one recorder.

● **Option**

Chart sensor: Detects paper-out to output an alarm.

● **Communication Interface**

INDIVIDUAL SPECIFICATIONS

Block	Item	Pen Model	Multi point Model	
Input Unit	Measuring Point	1, 2	6	
	Input Sampling	125ms	10s/6ch	
	Display Interval	2.5s	2.5s	
Record & Printer	Recording Form	Disposable felt pen	Wire dot with 6-color ink ribbon	
	Printing Form	Wire dot (one color ink ribbon)		
	Recording Width	100 mm		
	Step Response	1.0s max. to 95% of step-wise input	-	
	Dot Print Interval	-	10s/ch (Note 2)	
	Chart Paper	Length : 16m, Width : 114 mm Folding width : 40 mm (Note3)		
	Chart Speed	5, 10, 15, 20, 25, 30, 40, 50, 60, 75, 80, 90, 100,120, 150, 160, 180, 200, 240, 300, 360, 375, 450, 600, 720, 750, 900, 1200, 1500, 1800, 2400, 3000, 3600, 4500, 4800, 5400, 6000, 7200, 9000, 10800, 12000 mm/h	0, 1, 2, 3, 4, 5, 10, 15, 20, 25, 30, 40, 50, 60, 75, 80, 90, 100,120, 150, 160, 180, 200, 240, 300, 360, 375, 450, 600, 720, 750, 900, 1200, 150 mm/h (Analog recording is not done during the chart speed setting 0 mm/h.)	
	Recording Color (Note1)	1 pen (Red), 2 pen (Green)	No.1 (Purple), No.2 (Red), No.3 (Green), No.4 (Blue), No.5 (Brown), No.6 (Black)	
Printing Color	Purple	Purple, Red, Green, Blue, Brown, Black		
Weight		1 pen: 2.0kg max., 2 pen: 2.5kg max,	1.5kg max.	
Power Consumption		30VA max. (at 100VAC)	25VA max. (at 100VAC)	

(Note 1) User-changeable arbitrary colors with set-up configuration.

(Note 2) User-selective interval from 10, 20, 30 and 60 seconds.

(Note 3) Clean Chart Paper: Length 12 m

MEASUREMENT RANGE

Warm-up time 30 minutes min.; No effect of vibration and shock of over recorder's resistibility.

The junction compensation accuracy is not calculated into digital readout accuracy and recording accuracy. The junction compensation accuracy is based on operating conditions: Temperature, $23 \pm 2^\circ\text{C}$; Humidity, $55 \pm 10\%\text{RH}$; Power source $85 \sim 264\text{V AC}$; Frequency, $50/60\text{Hz} \pm 1\%$;

Junction compensation accuracy:

B, R, S, Au-Fe, PR40-20 $\pm 1^\circ\text{C}$
K, E, J, T, C, N, PLII, U, L $\pm 0.5^\circ\text{C}$

Type	Range	Measurement range	Measurement		
			Digital		Analog
			Accuracy	Max. Resolution	Accuracy
DC Voltage/ Current Input		- 10.00 ~ 10.00mV	$\pm(0.2\%$ of rdg + 3digits)	10 μV	Digital accuracy $\pm(0.3\%$ of span)
		0.00 ~ 20.00mV	$\pm(0.2\%$ of rdg + 3digits)	10 μV	
		0.00 ~ 50.00mV	$\pm(0.2\%$ of rdg + 2digits)	10 μV	
		- 200.0 ~ 200.0mV	$\pm(0.2\%$ of rdg + 3digits)	100 μV	
		- 1.000 ~ 1.000V	$\pm(0.1\%$ of rdg + 3digits)	1mV	
		0.000 ~ 5.000V	$\pm(0.2\%$ of rdg + 2digits)	1mV	
		- 10.00 ~ 10.00V	$\pm(0.3\%$ of rdg + 3digits)	10mV	
		4 ~ 20mA	$\pm(0.2\%$ of rdg + 2digits)	0.01mA	
Thermo- couple	B	0.0 ~ 1820.0 $^\circ\text{C}$	$\pm(0.15\%$ of rdg + 1 $^\circ\text{C}$) (Note 1)	0.1 $^\circ\text{C}$	Digital accuracy $\pm(0.3\%$ of span)
	R1	0.0 ~ 1760.0 $^\circ\text{C}$	$\pm(0.15\%$ of rdg + 1 $^\circ\text{C}$) (Note 2)		
	R2	0.0 ~ 1200.0 $^\circ\text{C}$	$\pm(0.15\%$ of rdg + 0.8 $^\circ\text{C}$) (Note 2)		
	S	0.0 ~ 1760.0 $^\circ\text{C}$	$\pm(0.15\%$ of rdg + 1 $^\circ\text{C}$) (Note 2)		
	K1	- 200.0 ~ 1370.0 $^\circ\text{C}$	$\pm(0.15\%$ of rdg + 0.7 $^\circ\text{C}$) (Note 3)		
	K2	- 200.0 ~ 600.0 $^\circ\text{C}$	$\pm(0.15\%$ of rdg + 0.4 $^\circ\text{C}$) (Note 3)		
	K3	- 200.0 ~ 300.0 $^\circ\text{C}$	$\pm(0.15\%$ of rdg + 0.3 $^\circ\text{C}$) (Note 3)		
	E1	- 200.0 ~ 800.0 $^\circ\text{C}$	$\pm(0.15\%$ of rdg + 0.5 $^\circ\text{C}$)		
	E2	- 200.0 ~ 300.0 $^\circ\text{C}$	$\pm(0.15\%$ of rdg + 0.4 $^\circ\text{C}$)		
	E3	- 200.0 ~ 150.0 $^\circ\text{C}$	$\pm(0.15\%$ of rdg + 0.3 $^\circ\text{C}$)		
	J1	- 200.0 ~ 1100.0 $^\circ\text{C}$	$\pm(0.15\%$ of rdg + 0.5 $^\circ\text{C}$) (Note 4)		
	J2	- 200.0 ~ 400.0 $^\circ\text{C}$	$\pm(0.15\%$ of rdg + 0.4 $^\circ\text{C}$) (Note 4)		
	J3	- 200.0 ~ 200.0 $^\circ\text{C}$	$\pm(0.15\%$ of rdg + 0.3 $^\circ\text{C}$) (Note 4)		
	T1	- 200.0 ~ 400.0 $^\circ\text{C}$	$\pm(0.15\%$ of rdg + 0.5 $^\circ\text{C}$) (Note 4)		
	T2	- 200.0 ~ 200.0 $^\circ\text{C}$	$\pm(0.15\%$ of rdg + 0.4 $^\circ\text{C}$) (Note 4)		
	C	0.0 ~ 2320.0 $^\circ\text{C}$	$\pm(0.15\%$ of rdg + 1 $^\circ\text{C}$)	0.1K	
	Au-Fe	1.0 ~ 300.0K	$\pm(0.15\%$ of rdg + 1K) (Note 5)		
	N	0.0 ~ 1300.0 $^\circ\text{C}$	$\pm(0.15\%$ of rdg + 0.7 $^\circ\text{C}$)		
	PR40-20	0.0 ~ 1880.0 $^\circ\text{C}$	$\pm(0.15\%$ of rdg + 1 $^\circ\text{C}$) (Note 6)	0.1 $^\circ\text{C}$	
	PLII	0.0 ~ 1390.0 $^\circ\text{C}$	$\pm(0.15\%$ of rdg + 0.7 $^\circ\text{C}$)		
	U	- 200.0 ~ 400.0 $^\circ\text{C}$	$\pm(0.15\%$ of rdg + 0.5 $^\circ\text{C}$) (Note 7)		
	L	- 200.0 ~ 900.0 $^\circ\text{C}$	$\pm(0.15\%$ of rdg + 0.5 $^\circ\text{C}$) (Note 7)		
Resistance Temperature Detector	Pt100-1	- 200.0 ~ 650.0 $^\circ\text{C}$	$\pm(0.15\%$ of rdg + 0.3 $^\circ\text{C}$)	0.1 $^\circ\text{C}$	Digital accuracy $\pm(0.3\%$ of span)
	Pt100-2	- 200.0 ~ 200.0 $^\circ\text{C}$	$\pm(0.15\%$ of rdg + 0.2 $^\circ\text{C}$)		
	JPt100-1	- 200.0 ~ 630.0 $^\circ\text{C}$	$\pm(0.15\%$ of rdg + 0.3 $^\circ\text{C}$)		
	JPt100-2	- 200.0 ~ 200.0 $^\circ\text{C}$	$\pm(0.15\%$ of rdg + 0.2 $^\circ\text{C}$)		

Note 1: 400 ~ 600 $^\circ\text{C}$: $\pm 2^\circ\text{C}$

A range under a span of 400 $^\circ\text{C}$: Accuracy is out of guarantee

Note 2: 0 ~ 100 $^\circ\text{C}$: $\pm 3.7^\circ\text{C}$ 100 ~ 300 $^\circ\text{C}$, $\pm 1.5^\circ\text{C}$

Note 3: - 200 ~ -100 $^\circ\text{C}$: $\pm (0.15\%$ of rdg + 1 $^\circ\text{C}$)

Note 4: - 200 ~ -100 $^\circ\text{C}$: $\pm (0.15\%$ of rdg + 0.7 $^\circ\text{C}$)

Note 5: 1 ~ 20 K: ± 2.4 K

Note 6: 0 ~ 300 $^\circ\text{C}$: $\pm 37.6^\circ\text{C}$ 300 ~ 800 $^\circ\text{C}$, $\pm 18.8^\circ\text{C}$

Note 7: - 200 ~ -100 $^\circ\text{C}$: $\pm (0.15\%$ of rdg + 0.7 $^\circ\text{C}$)

STANDARD FUNCTIONS

Item	Description
Analog recording	Pen Models: Continuous pen tracing Multi point Model: Dot printing with 6-color ribbon cartridge
Digital display	Indicates channel no., process variable, date, chart speed, alarm set point in front display.
Logging print	Prints date, time, scale, chart speed, each channel's process variable and engineering unit at a programmed interval.
List print	Prints chart speed, type of input, range, engineering unit, alarm set point, comment print status, Printing description, logging print ON/OFF configuration, ZONE recording configuration, point focus configuration
Engineering list print	Prints configuration of channel/tag print switch, alarm print, logging print ON/OFF, reference time, interval, alarm hysteresis, burnout protection, scaling print ON/OFF, DI function (option)
Affix print (Multipoint Model)	Prints Channel number besides analog recording line.
Manual print	Prints measured data by the front key operation. Analog recording stops during manual printing.
Skip (Multipoint model)	Abandon dot print of inputs as required.
Programming	Programs chart speed, alarm set point, logging print interval, skip, date and time.
Memory Backup	Back-up for clock by built-in lithium battery for 10 years, 5 years in unpowered state. A non-volatile memory stores configuration and calibration data.
Alarm	Sets 2 types (H, L) of alarms per channel. Sets a total of 4 levels.
Chart Speed	Selects Chart speed from 41 types.
Clock Indication	Indicates Year, Month, Day, Hour and Minute. Sets the year in A.D, and adjusts leap year automatically.
Self Diagnostics	Occurring some type of the defect to indicate "ERROR".
Scaling	Indicates and record the input of a unification signal etc. is changed into the engineering scales.

CONFIGURABLE FUNCTIONS

Function	Description
Burnout protection	Sets pointer at over 100% per inputs when input becomes open for T/C or $\pm 50\text{mV}$ max. input.
Tag Number	Tag number up to 5 characters for pen models/7 characters for multipoint model per channel can be programmed, and prints at logging print.
Temperature Compensation	Inside/outside of reference junction compensation (DE/DH connection) can be specified.
Copy Function	Channel configuration data can be copied to another channel.
Input offset	Input offset per channel can be programmed.
ZONE Recording	Recording on the chart track in specified range per channel.
Point focus recording	Recording by point focus to 1-crease line per channel.
Decade Recording • Indicating	Records and indicates up to 5 decades. 2 figures of effective number to indicate and print.
Alarm print	Prints time, channel number, setting number and type of alarm in alarming.
Alarm recovery print	Prints recovery time, recovery channel number, setting number and type of alarm at recovery.
Record start/end print	Prints time and comment ("Start" or "End") when record beginning or end.
Square root	Square root available.
Integration	Sum, balance, average among channels can be integrated.
Damping (Pen Model)	Digital filtering for measured data (PV) in unsteady process. Filter constant range ability: 1.0000 to 0.0001 Formula is: $k = 0.64/T_1$ k = Filter constant T_1 = 99.5% damping
Alarm Hysteresis Width	Alarm hysteresis width can be programmed at 0% FS or 0.5% FS.

(Unit = mm)

DIMENSIONS

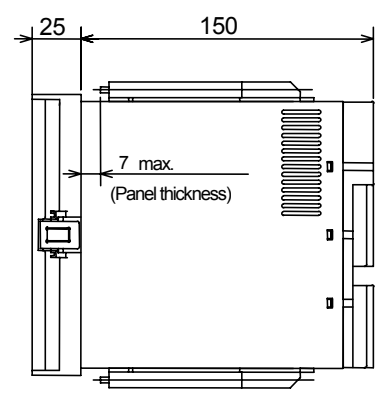
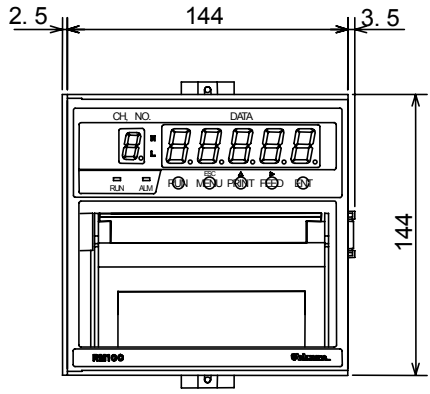

Panel Cutout (mm)

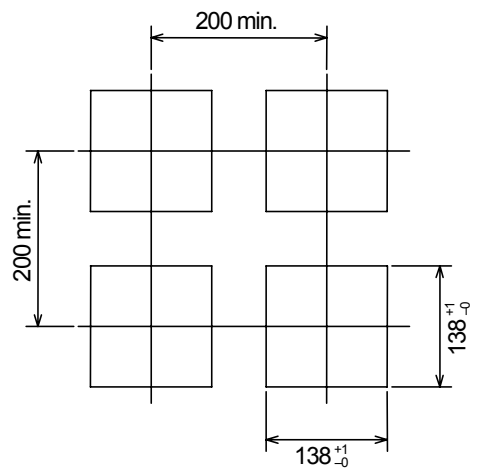

TERMINAL ARRANGEMENT

Multipoint Model

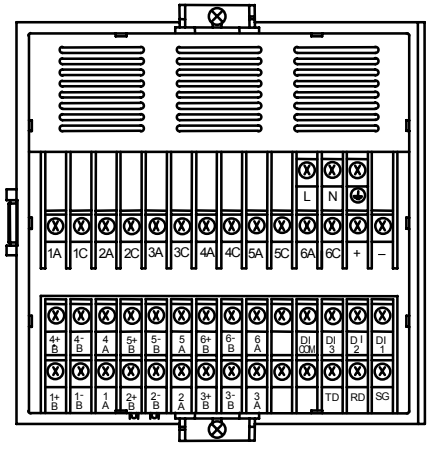

Pen Model

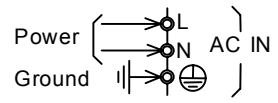
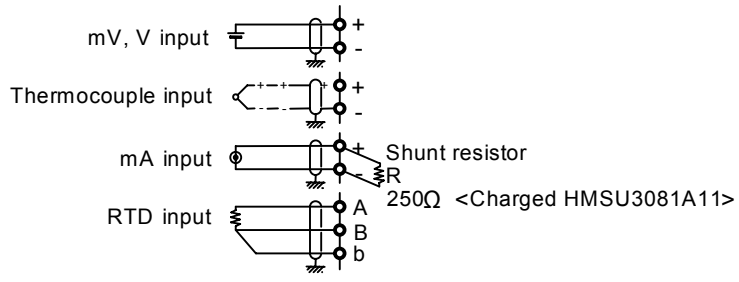
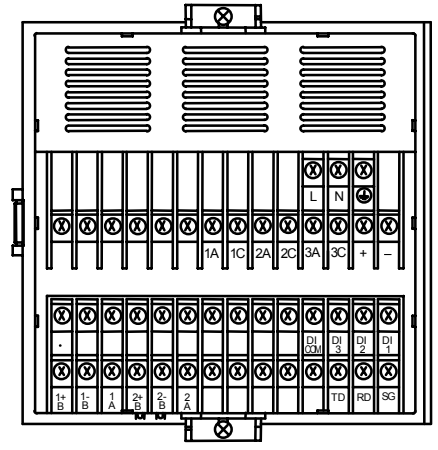

MODEL CODE NUMBER

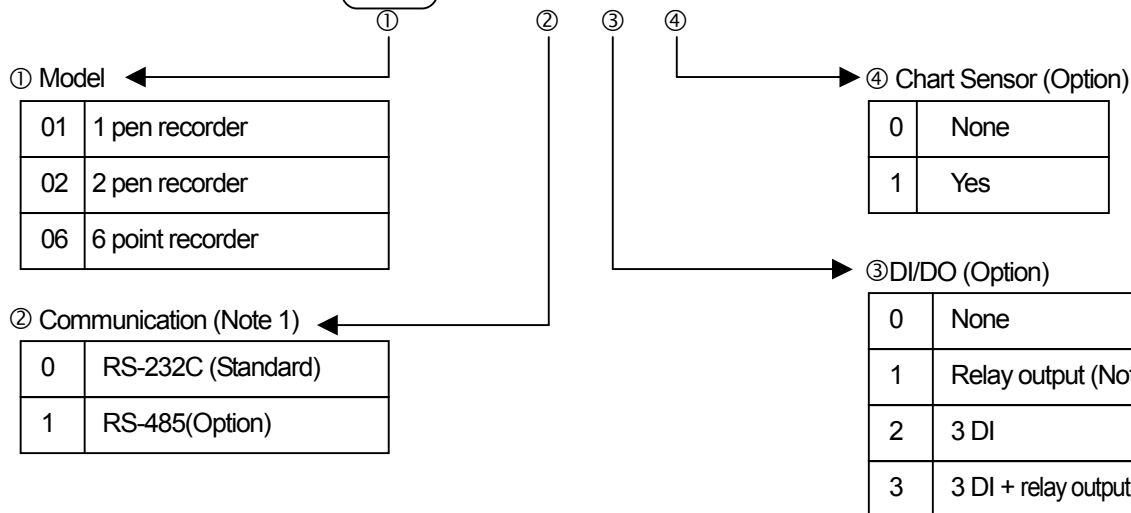
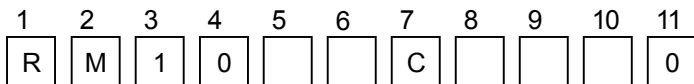

(Note 1) Combination of RS-232C and RS-485 unavailable.

(Note 2) Nos. of relay outputs:
 6 point recorder 6 relays; Pen recorder 3 relays

⚠ CAUTION

Do not install this device before consulting instruction manual

Specifications are subject to change without notice.
 For further information, a quotation or a demonstration please contact to: