

# LINEARLY SPEED / RPM CONTROLLER

CS2-RL(1.4)

## FEATURE

- Measuring Frequency **0.001~100KHz / ~140KHz(optional)** / Contact, NPN, PNP, Voltage pulse
- Accuracy:  $\pm 0.005\%$ ; Display range: 0~99999 with **D.P. auto moving**
- User function, easily programmed by the front panel
- **4 relay for Hi / Lo / Go / DO energized with Start Delay / Hysteresis / Energized & De-energized Delay / Relay Energized Hold..... functions**
- Analogue output and RS 485 communication port in option
- **3 external control inputs for Relative PV / PV Hold / Maximum or Minimum Hold / DI / Reset for Relay Energized Hold....**
- CE approved



The Newest

## ORDER INFORMATION

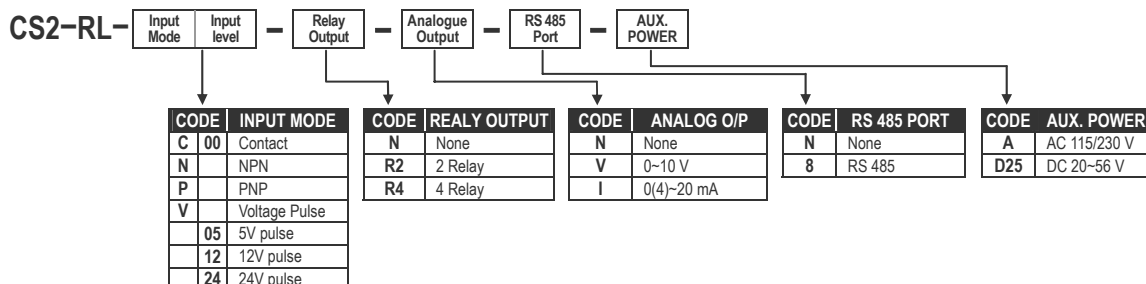

## SPECIFICATION

Input Frequency	Input Mode	Input Level
0.001~50 Hz	Contact	
0.001~50 Hz	NPN	High Level: 8~12V; Low Level: 0.0~4.0 V (with excitation supply 12Vdc)
0.001~100 KHz	PNP	
<b>0.001~140 KHz (optional)</b>	Voltage Pulse	High Level: over 2/3 of input level Low Level: under 1/3 of input level

➤ **Input Mode & Level changeable by dip switch of rear terminal block.**

- Calibration: Without calibration process.
- Accuracy:  $\leq \pm 0.005\%$  of RDG  $\pm 1C$ ;
- Sampling time: 10 cycles/sec ( $\geq 10Hz$ );  
f cycles/sec ( $\leq 10Hz$ )
- Response time:  $\leq 100$  msec (when the AvG = "1")
- Operating**
- Operation key: 4 keys for Enter(Function) / Shift(Escape) / Up / Down  
Up key: increase the number / back to previous function  
Up key: increase the number / back to previous  
Down key: decrease the number / go to next function  
Shift/Escape key: move the flash digit position / Return back to upper level  
Enter/Fun key: enter the parameters you set or function select
- Security function: 4 digits password
- Lock function: 3 function group lock level for None/User Level/ Engineer Level / All(Engineer Level & User Level)

### Display & functions

- LED: Measuring value: 0.56" red high-brightness LED  
Relay output indication: square red LED  
External control input: square green LED  
RS 485 communication: square red LED  
Max. / Mini. Hold: square red LED
- Low Cut function: Low.cut :Settable range: 000~5000 counts
- Average function: AvG :Settable range: 1~99 times
- Digital Filter: D.FiLt : Settable range: 0(None)/1~99 times
- Over range indication: ovFL, when input is over 120% of input range Hi
- Reading functions**
- Input range: 0.001~100KHz  
**0.001~140KHz specify in option**
- Resolution: **Auto / Semi-Auto / Fix; 3 mode selectable**  
(Auto-Moving for d.p.) **Decimal point will Auto-changed according to input**

- Compensation factor: Compensate error from 0.0001~9.9999
- Over range indication: ovFL, when input is over 120% of input range Hi
- Display functions: **Measuring Value / Maximum Hold / Minimum Hold / Reading value from RS485 command**

### Max. (or Mini.) Hold & Reset

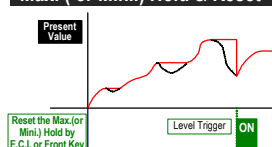

### Data Hold & Reset

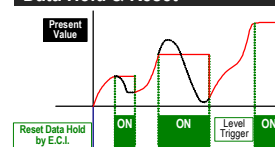

### Control functions

- Control relay: 2 Relays SPDT, 5A/230Vac, 10A/115V  
2 Relays SPST, 1A/230Vac, 3A/115V
- Relay Output: Energized levels compare with set-points:  
**Hi / Lo / Hi.HLd / Lo.HLd / do / Go-1.2 / Go-2.3**  
**DO function: Energized by RS485 command**  
**Relay Energized Hold : Selectable Low or High Hold**

### Hi / Lo / Go Relay Energized

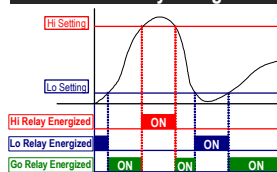

### Hi(Lo) Energized Hold & Reset

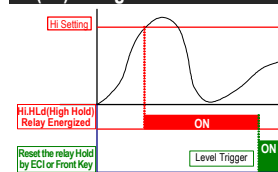

- Functions: Start delay / Energized & De-energized delay / Hysteresis  
Start band: 0~9999 counts  
Start delay time: 0:00.0~9(M):59.9(S)  
**Energized & De-energized delay time: 0:00.0~9:59.9**  
Hysteresis: 0~5000 counts

### Start Delay

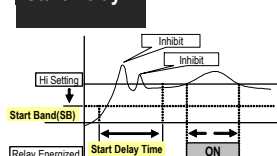

### Energized / De-energized Delay & Hysteresis

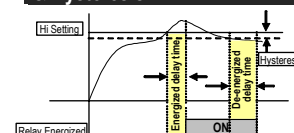

# LINEARLY SPEED / RPM CONTROLLER

CS2-RL(1.4)

## External Control Inputs(ECI)

- Input mode: 3 ECI points, Contact or open collect input
- Functions: *Relative PV / PV Hold / Reset Max or Mini. Hold / DI / Reset for Relay Energized Hold*  
 Debouncing time: 5 ~ 255 x 8mseconds

## Analogue output(option)

- Accuracy:  $\leq \pm 0.1\%$  of F.S.; 16 bits AD converter
  - Ripple:  $\leq \pm 0.1\%$  of F.S.
  - Response time:  $\leq 200$  msec. (10~90% of input)
  - Isolation: AC 2.0 KV between input and output
  - Output range: Specify Voltage or Current  
 Voltage: 0~5V / 0~10V / 1~5V selectable  
 Current: 0~10mA / 0~20mA / 4~20mA selectable
- Ao.Hi(output high): PV Hi vs. output range Hi**  
**Ao.Lo(output range Low): PV Low vs. output range**  
**Ao.LM(output High Limit):**  
 0.00~110.00% of output High

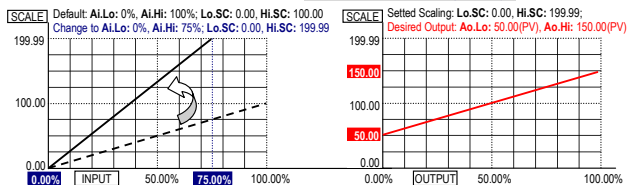

## RS 485 communication(optional)

- Protocol: Modbus RTU mode  
 Baud rate: 2400/4800/9600/19200/38400  
 Data bits: 7 or 8 bit  
 Parity: Even, odd or none (with 1 or 2 stop bit)  
 Device no: 1 ~ 255
- Read function: Read value from PC's RS485 command

## Power

- Excitation Supply: DC 12V, 30mA
- Power Supply: AC 115/230V  $\pm 10\%$ , 50/60Hz  
 Optional DC 20~56V
- Power consumption: 5.0VA
- Back up memory: By EEPROM

## Environmental

- Operating temperature: 0~60 °C
- Operating relative humidity: 20~95 %RH, Non-condensing
- Temperature coefficient:  $\leq 100$  PPM/°C
- Storage temperature: -10~70 °C
- Enclosure: Front panel: IEC 549 (IP54)

## Electrical safety

- Dielectric Strength: AC 2.0 KV for 1 min  
 Between Power / Input / Output / Case
- Insulation resistance:  $\geq 100M$  ohm at 500Vdc
- Isolation: Between Power / Input / Output
- EMC: EN61326
- Safety: EN61010

## Mechanical

- Dimensions: 96mm(W) x 48mm(H) x 120mm(D)
- Panel cutout: 92mm(W) x 44mm(H)
- Case Material: ABS fire-protection (UL 94V-0)
- Mounting: Panel flush mounting
- Terminal block: Plastic NYLON 66 (UL 94V-0)  
 10A/300Vac, M2.6, 16~22AWG
- Weight: 550g

## FRONT PANEL

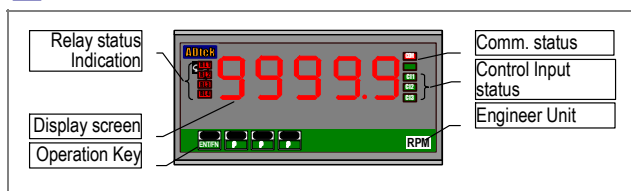

## DIMENSIONS

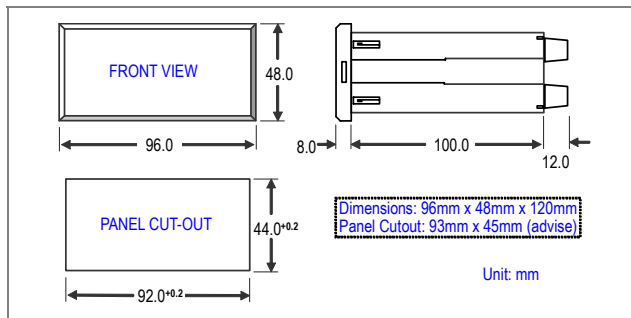

## INSTALLATION

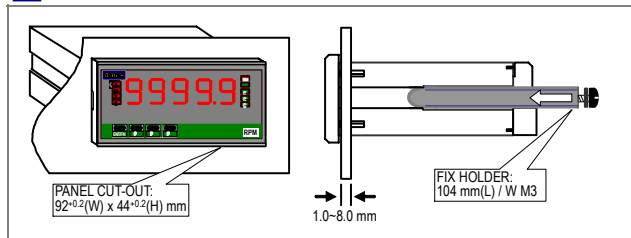

## CONNECTION DIAGRAM

